

# JK TAILGATE REINFORCEMENT

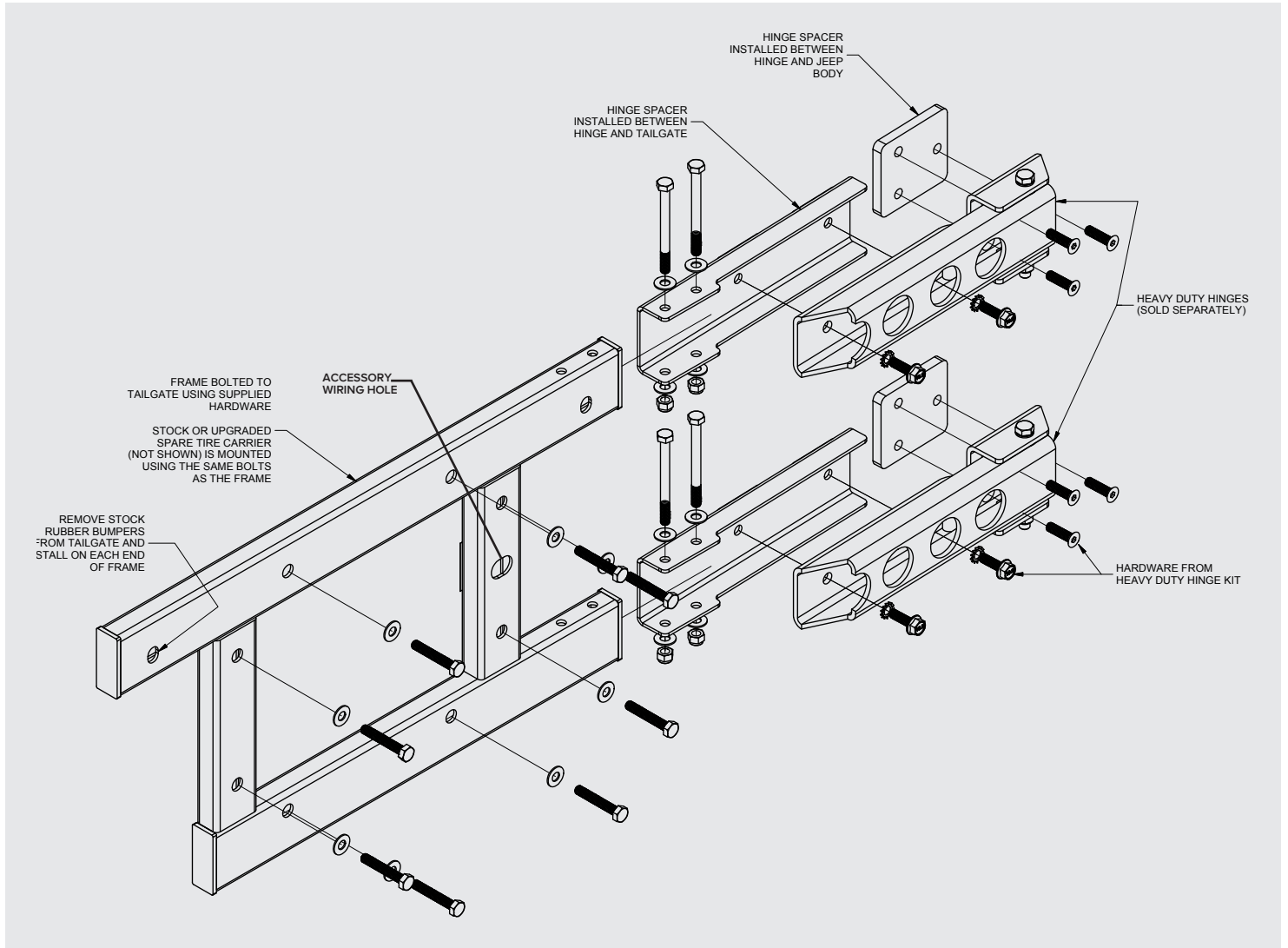

1. Remove spare tire, spare tire carrier, rubber spare tire bumpers, and the accessory plug located to the right of the spare carrier.
2. Seal the two rubber bumper holes in the tailgate with the provided tape. Also seal the accessory wiring hole in the tailgate if that hole isn't being used for a CB antenna wire or other accessory wiring. Make sure the area around the holes is clean prior to applying tape.
3. With the tailgate closed and latched remove the top hinge.
4. Install Heavy Duty hinge on top of provided hinge spacers. Install all bolts most of the way but do not tighten completely.
5. Repeat process with bottom hinge.
6. Align reinforcement frame with stock spare tire carrier mounting holes and holes in the tailgate hinge spacer.
7. Install provided bolts through hinge spacer and reinforcement frame. Do not tighten.

# JK TAILGATE REINFORCEMENT

## (CONTINUED)

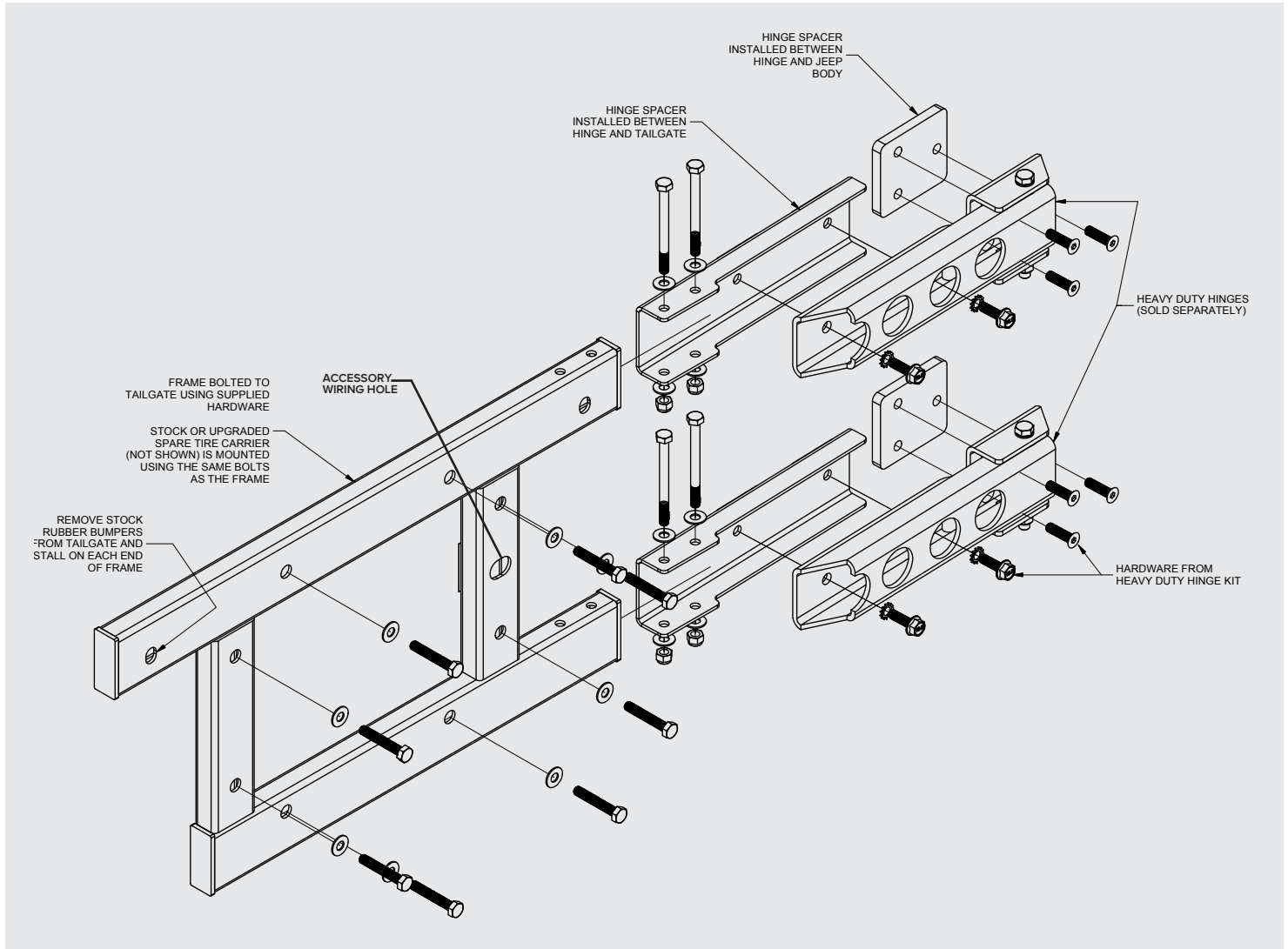

8. Connect stock or upgraded spare tire carrier and reinforcement frame to tailgate using hardware provided and tighten bolts. Apply anti-seize to these bolts before installing.
9. Once spare tire carrier is installed tighten the bolts connecting the frame to the hinge spacers and all of the hinge bolts.
10. Finish by installing the rubber spare tire bumpers into the slots on each end of the reinforcement frame. The accessory wiring hole plug that was removed from the tailgate can be inserted into the accessory wiring hole in the reinforcement frame.
11. If stock spare tire bumpers do not contact tire due to wheel/tire combination it is recommended an alternative be used to ensure the spare tire is secured properly (ie. Daystar Tailgate Bump Stops).