

# MOUNTING THE OFFROAD JACK CARRIER

\*Easily mounts to the Heavy-Duty JK hinges, sold separately

1. Remove spare tire and insert backer clip into middle hole in upper heavy duty hinge
2. Hold backer clip in place with a finger through one of the adjacent holes
3. Insert bolt through the right side of the upper bracket and thread it into the backer clip
4. Repeat with the left side of the upper bracket
5. Attach the lower tray with bolts and backer clips using the middle and right holes on the lower heavy duty hinge
6. Install carriage bolt into upper bracket, install washer and tighten jam nut to hold bolt in place
7. Place base of hi-lift jack into the lower tray, with the base resting in the tray one of the holes in the bar of the jack should fit over the carriage bolt
8. The upper bracket and lower tray can be adjusted vertically to get a hole to align with the carriage bolt, the lower tray can also be adjusted side to side to get the jack to sit vertically
9. Once the bracket and tray are adjusted tighten bolts to secure to hinges
10. Use the lock nut to secure the bar of the jack to the upper bracket using the Wrangler's lug wrench
11. The use of a handle keeper (not included) on the jack is recommended to secure the handle to the bar during transportation

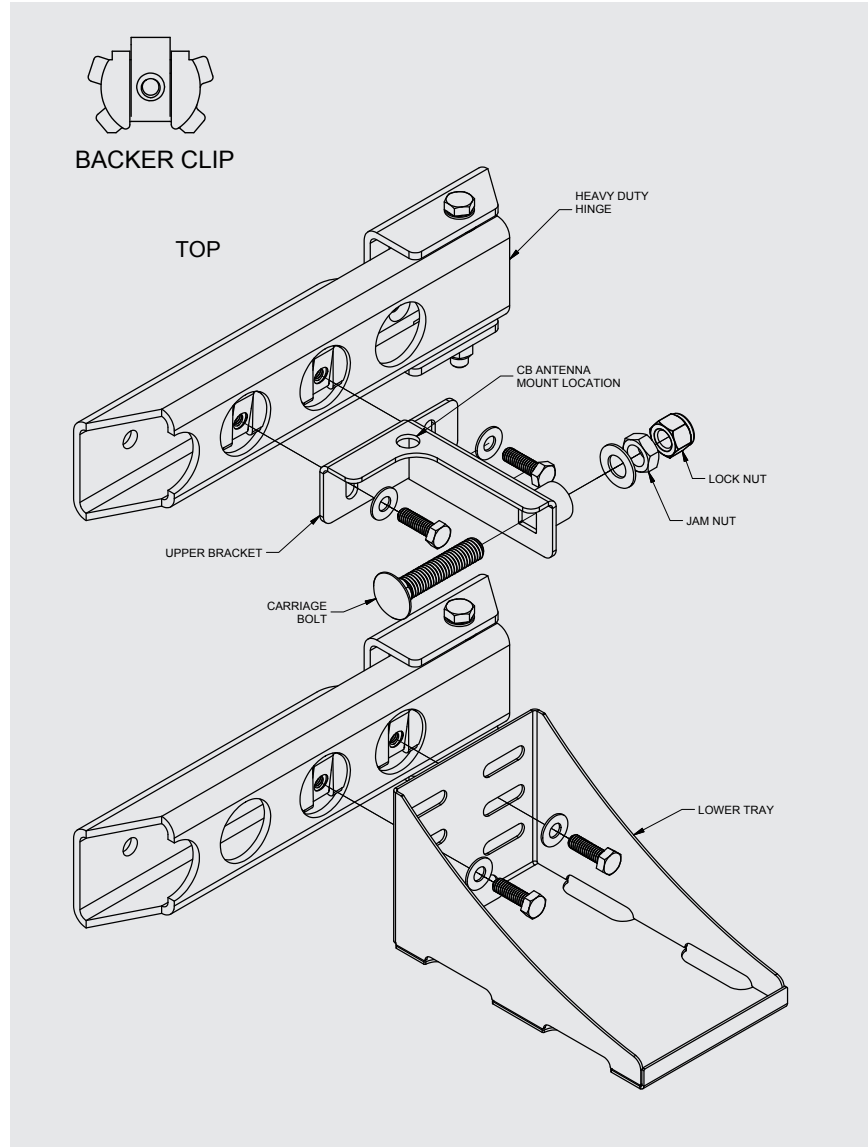

**NOTE:** • Process is much easier if spare tire is removed before installation  
• Maximum spare tire size compatible with the carrier is 35"